

AACM-R Series

Features

- Qualified to AEC-Q200.
- Low profile (h=2.5mm)
- Small size (5.0x4.5mm) and high rated current (1.5 to 6A)
- High common mode Impedance (max. 1400 ohm, at 100MHz)

Applications

- Noise suppression for power line
- Power line equipment
 - DC-DC converters
 - Battery chargers
- Portable equipment
 - PDAs (Personal Digital Assistants)
 - Note PCs
 - Printers

Test Conditions

- All test data is referenced to 25°C ambient.
- Operating temperature range -40°C to +125°C(Including self - temperature rise).
- The part temperature(ambient + temp rise)should not exceed 125°C under worst case operating conditions. Circuit design,component placement, PCB trace size and thickness,airflow and other cooling provisions all affect the part temperature,part temperature should be verified in the end application.

External dimensions (Unit:mm)

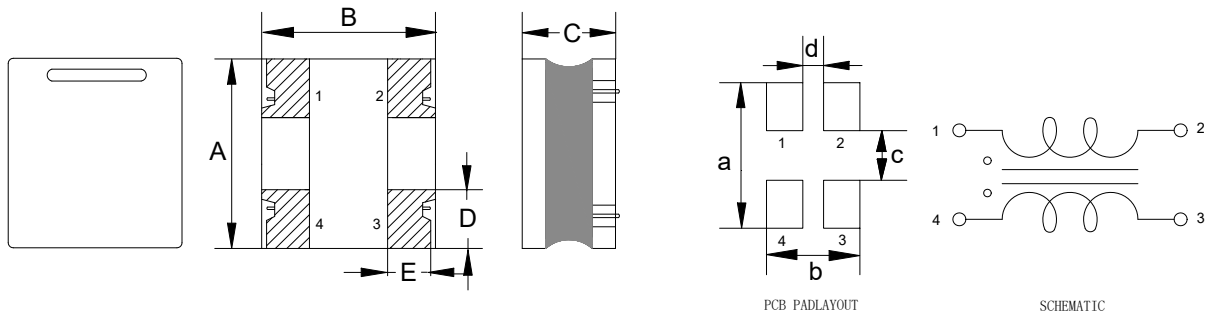

Type	A	B	C	D	E	a	b	c	d	Q'Ty/Reel
AACM05R25	5.0±0.3	4.5±0.3	2.5Max	2.1±0.3	1.1±0.3	5.5	4.6	1.5	1.2	2500

Part Number Code

AACM 05 R 25 R 101
 A B C D E F

A: Series Name Common Mode Chokes
 B: Dimensions(mm) 05: 5.0x4.5
 C: Materials R Type
 D: Thickness(mm) 25: 2.5Max
 E: Tolerance R: Reference
 F: Impedance 101=100Ω

Electrical Characteristics

Part Number	Common Mode Impedance @100MHz	Rated current	DC Resistance	Rated Voltage	Withstand Voltage	Insulation Resistance
	(Ω)Typ.	(A)Max	(Ω) $\pm 40\%$	(V)Typ.	(V)Typ.	(M Ω)Min.
AACM05R25R101	100	6	0.009	50	125	10
AACM05R25R251	250	5	0.014			
AACM05R25R501	500	4	0.019			
AACM05R25R102	1000	3	0.024			
AACM05R25R142	1400	1.5	0.040			

Characteristics Curve (Reference)

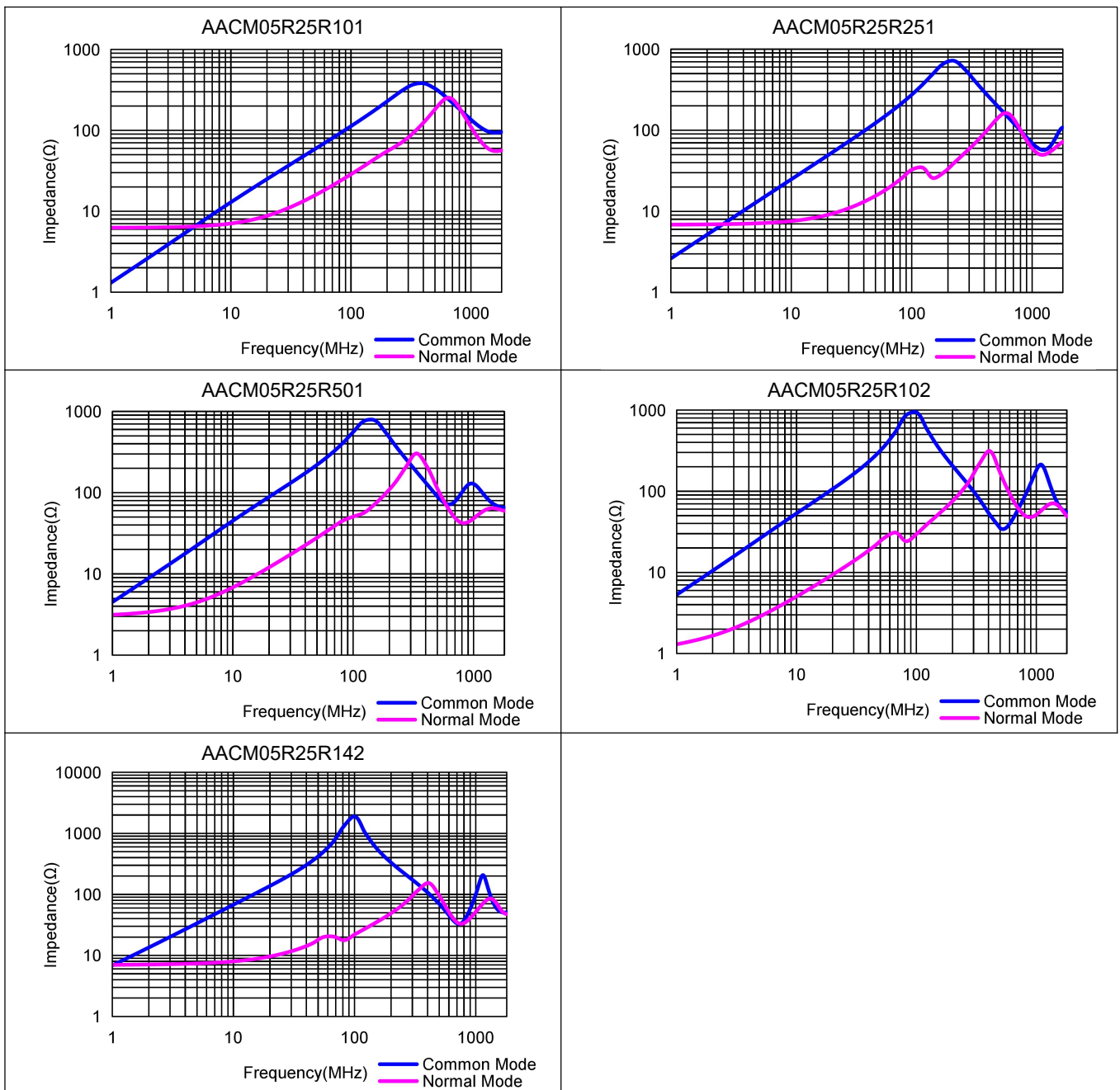

Reliability Test

Item	Specifications	Test conditions
6.1 High temperature storage test	No visible mechanical damage. Impedance change: Within $\pm 15\%$.	<p>Temperature: $125 \pm 2^\circ\text{C}$. Duration: 1000hrs. Measured at room temperature after placing for 24 ± 4 hrs.</p>
6.2 Temperature cycling test	No visible mechanical damage. Impedance change: Within $\pm 15\%$.	<p>Condition for 1 cycle. Step1: $-40 \pm 2^\circ\text{C}$ 30min Min. Step2: $125 \pm 2^\circ\text{C}$, transition time 1min Max. Step3: $125 \pm 2^\circ\text{C}$ 30min Min. Step4: Low temp, transition time 1min Max. Number of cycles: 1000. Measured at room temperature after placing for 24 ± 4 hrs.</p>
6.3 Biased humidity test	No visible mechanical damage. Impedance change: Within $\pm 15\%$.	<p>Humidity : $85\% \pm 3$ RH. Temperature: $85^\circ\text{C} \pm 2^\circ\text{C}$. Duration : 1000hrs. Measured at room temperature after placing for 24 ± 4 hrs.</p>
6.4 Operational life test	No visible mechanical damage. Impedance change: Within $\pm 15\%$.	<p>Temperature: $105 \pm 2^\circ\text{C}$. Duration : 1000hrs. Measured at room temperature after placing for 24 ± 4 hrs.</p>
6.5 Resistance to solvent test	No visible mechanical damage. Impedance change: Within $\pm 15\%$.	Add aqueous wash chemical - OKEM clean or equivalent.
6.6 Vibration test	No visible mechanical damage. Impedance change: Within $\pm 15\%$.	<p>Oscillation Frequency: 10~2K~10Hz for 20 minute. Total Amplitude: $1.52\text{mm} \pm 10\%$. Testing Time : 12 hours(20 minutes, 12 cycles each of 3 orientations).</p>

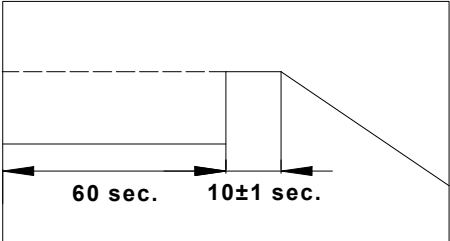
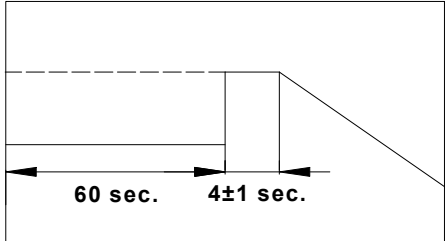
Item	Specifications	Test conditions
<p>6.7 Resistance to soldering heat test</p>	<p>No visible mechanical damage. Impedance change: Within $\pm 15\%$.</p>	<p>Temperature ($^{\circ}\text{C}$): 260 ± 5 (solder temp). Time (s): 10 ± 1. ramp/immersion and emersion rate: $25\text{mm/s} \pm 6 \text{ mm/s}$. Number of heat cycles:1.</p> 
<p>6.8 Solderability test</p>	<p>More than 95% of the terminal electrode should be covered with solder.</p>	<p>Steam Aging: 8 hours \pm 15 min. Preheat: 150°C, 60sec. Solder: Sn99.5%-Cu0. 5%. Temperature: $245 \pm 5^{\circ}\text{C}$. Flux for lead free: Rosin. 9.5%. Dip time: 4 ± 1sec. Depth: completely cover the termination.</p> 
<p>6.9 Terminal strength (SMD) test</p>	<p>No visible mechanical damage.</p>	<p>With the component mounted on a PCB with the device to be tested, apply a 17.7 N (1.8 Kg) force to the side of a device being tested. This force shall be applied for 60 ± 1 seconds. Also the force shall be applied radually as not to apply a shock to the component being tested.</p>

Packaging(Unit:mm)

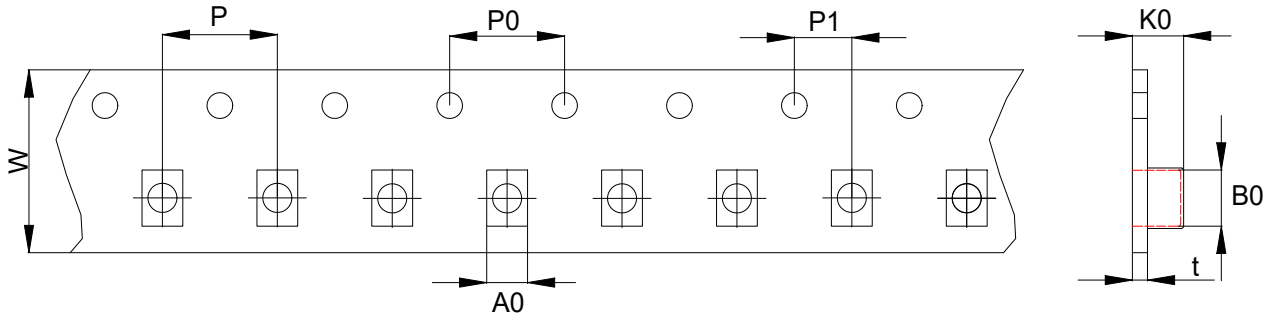

Type	W	P	P0	P1	A0	B0	K0	t
AACM05R25	12.0±0.2	8.0±0.1	4.0±0.1	2.0±0.1	4.8±0.1	5.3±0.1	2.5±0.1	0.25±0.05

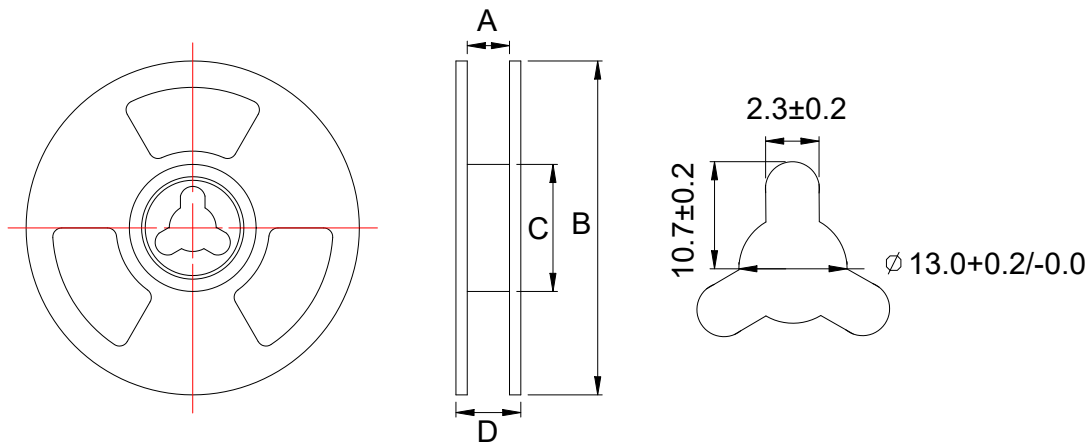

Type	A	B	C	D
AACM05R25	12.5±2.0	330.0±2.0	100.0±2.0	16.5±2.0

Recommended Soldering Technologies

Re-flowing Profile:

- △ Preheat condition: 150~200°C/60~120sec.
- △ Allowed time above 217°C: 60~90sec.
- △ Max temp: 260°C
- △ Max time at max temp: 5sec.
- △ Solder paste: Sn/3.0Ag/0.5Cu
- △ Allowed Reflow time: 2x max

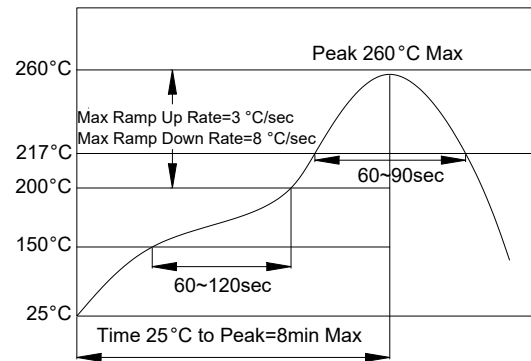

Iron Soldering Profile:

- △ Iron soldering power: Max.30W
- △ Pre-heating: 150°C/60sec.
- △ Soldering Tip temperature: 350°CMax.
- △ Soldering time: 3sec Max.
- △ Solder paste: Sn/3.0Ag/0.5Cu
- △ Max.1 times for iron soldering

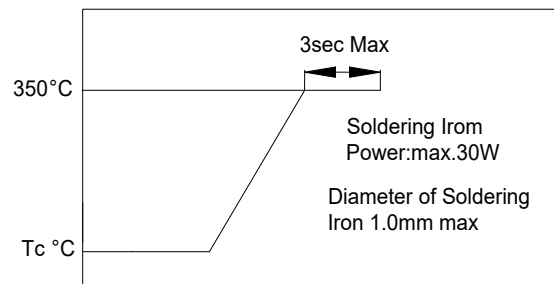

[Note: Take care not to apply the tip of the soldering iron to the]